

XTRA™ Series

Half-Rack Audio Power Amplifiers



Extron® Electronics
INTERFACING, SWITCHING AND CONTROL

Safety Instructions

Safety Instructions • English

WARNING: This symbol, ⚠, when used on the product, is intended to alert the user of the presence of uninsulated dangerous voltage within the product's enclosure that may present a risk of electric shock.

ATTENTION: This symbol, ⚠, when used on the product, is intended to alert the user of important operating and maintenance (servicing) instructions in the literature provided with the equipment.

For information on safety guidelines, regulatory compliances, EMI/EMF compatibility, accessibility, and related topics, see the Extron Safety and Regulatory Compliance Guide, part number 68-290-01, on the Extron website, www.extron.com.

Instructions de sécurité • Français

AVERTISSEMENT: Ce pictogramme, ⚠, lorsqu'il est utilisé sur le produit, signale à l'utilisateur la présence à l'intérieur du boîtier du produit d'une tension électrique dangereuse susceptible de provoquer un choc électrique.

ATTENTION: Ce pictogramme, ⚠, lorsqu'il est utilisé sur le produit, signale à l'utilisateur des instructions d'utilisation ou de maintenance importantes qui se trouvent dans la documentation fournie avec le matériel.

Pour en savoir plus sur les règles de sécurité, la conformité à la réglementation, la compatibilité EMI/EMF, l'accessibilité, et autres sujets connexes, lisez les informations de sécurité et de conformité Extron, réf. 68-290-01, sur le site Extron, www.extron.fr.

Sicherheitsanweisungen • Deutsch

WARNUNG: Dieses Symbol ⚠ auf dem Produkt soll den Benutzer darauf aufmerksam machen, dass im Inneren des Gehäuses dieses Produktes gefährliche Spannungen herrschen, die nicht isoliert sind und die einen elektrischen Schlag verursachen können.

VORSICHT: Dieses Symbol ⚠ auf dem Produkt soll dem Benutzer in der im Lieferumfang enthaltenen Dokumentation besonders wichtige Hinweise zur Bedienung und Wartung (Instandhaltung) geben.

Weitere Informationen über die Sicherheitsrichtlinien, Produkthandhabung, EMI/EMF-Kompatibilität, Zugänglichkeit und verwandte Themen finden Sie in den Extron-Richtlinien für Sicherheit und Handhabung (Artikelnummer 68-290-01) auf der Extron-Website, www.extron.de.

Instrucciones de seguridad • Español

ADVERTENCIA: Este símbolo, ⚠, cuando se utiliza en el producto, avisa al usuario de la presencia de voltaje peligroso sin aislar dentro del producto, lo que puede representar un riesgo de descarga eléctrica.

ATENCIÓN: Este símbolo, ⚠, cuando se utiliza en el producto, avisa al usuario de la presencia de importantes instrucciones de uso y mantenimiento recogidas en la documentación proporcionada con el equipo.

Para obtener información sobre directrices de seguridad, cumplimiento de normativas, compatibilidad electromagnética, accesibilidad y temas relacionados, consulte la Guía de cumplimiento de normativas y seguridad de Extron, referencia 68-290-01, en el sitio Web de Extron, www.extron.es.

Инструкция по технике безопасности • Русский

ПРЕДУПРЕЖДЕНИЕ: Данный символ, ⚠, если указан на продукте, предупреждает пользователя о наличии неизолированного опасного напряжения внутри корпуса продукта, которое может привести к поражению электрическим током.

ВНИМАНИЕ: Данный символ, ⚠, если указан на продукте, предупреждает пользователя о наличии важных инструкций по эксплуатации и обслуживанию в руководстве, прилагаемом к данному оборудованию.

Для получения информации о правилах техники безопасности, соблюдении нормативных требований, электромагнитной совместимости (ЭМП/ЭДС), возможности доступа и других вопросах см. руководство по безопасности и соблюдению нормативных требований Extron на сайте Extron: www.extron.ru, номер по каталогу - 68-290-01.

Chinese Simplified (简体中文)

警告: ⚠ 产品上的这个标志意在警告用户该产品机壳内有暴露的危险电压,有触电危险。

注意: ⚠ 产品上的这个标志意在提示用户设备随附的用户手册中有重要的操作和维护(维修)说明。

关于我们产品的安全指南、遵循的规范、EMI/EMF 的兼容性、无障碍使用的特性等相关内容, 敬请访问 Extron 网站 www.extron.cn, 参见 Extron 安全规范指南, 产品编号 68-290-01。

Chinese Traditional (繁體中文)

警告: ⚠ 若產品上使用此符號, 是為了提醒使用者, 產品機殼內存在著可能會導致觸電之風險的未絕緣危險電壓。

注意: ⚠ 若產品上使用此符號, 是為了提醒使用者。

有關安全性指導方針、法規遵守、EMI/EMF 相容性、存取範圍和相關主題的詳細資訊, 請瀏覽 Extron 網站: www.extron.cn, 然後參閱《Extron 安全性與法規遵守手冊》, 準則編號 68-290-01。

Japanese

警告: この記号 ⚠ が製品上に表示されている場合は、筐体内に絶縁されていない高電圧が流れ、感電の危険があることを示しています。

注意: この記号 ⚠ が製品上に表示されている場合は、本機の取扱説明書に記載されている重要な操作と保守(整備)の指示についてユーザーの注意を喚起するものです。

安全上のご注意、法規遵守、EMI/EMF適合性、その他の関連項目については、エクストロンのウェブサイト www.extron.jp より『Extron Safety and Regulatory Compliance Guide』(P/N 68-290-01) をご覧ください。

Korean

경고: 이 기호 ⚠ 가 제품에 사용될 경우, 제품의 인클로저 내에 있는 접지되지 않은 위험한 전류로 인해 사용자가 감전될 위험이 있음을 경고합니다.

주의: 이 기호 ⚠ 가 제품에 사용될 경우, 장비와 함께 제공된 책자에 나와 있는 주요 운영 및 유지보수(정비) 지침을 경고합니다.

안전 가이드라인, 규제 준수, EMI/EMF 호환성, 접근성, 그리고 관련 항목에 대한 자세한 내용은 Extron 웹 사이트(www.extron.co.kr)의 Extron 안전 및 규제 준수 안내서, 68-290-01 조항을 참조하십시오.

FCC Class B Notice

FC This equipment has been tested and found to comply with the limits for a Class B digital device, pursuant to part 15 of the FCC rules. These limits provide reasonable protection against harmful interference in a residential installation. This equipment generates, uses, and can radiate radio frequency energy and, if not installed and used in accordance with the instructions, may cause harmful interference to radio communications. There is no guarantee that interference will not occur. If this equipment does cause interference to radio or television reception, which can be determined by turning the equipment off and on, you are encouraged to try to correct the interference by one or more of the following measures:

- Reorient or relocate the receiving antenna.
- Increase the separation between the equipment and receiver.
- Connect the equipment into an outlet on a circuit different from that to which the receiver is connected.
- Consult the dealer or an experienced radio/TV technician for help.

NOTE: For more information on safety guidelines, regulatory compliances, EMI/EMF compatibility, accessibility, and related topics, see the [“Extron Safety and Regulatory Compliance Guide”](#) on the Extron website.

Conventions Used in this Guide

Notifications

The following notifications are used in this guide:

WARNING: A warning indicates a situation that has the potential to result in death or severe injury.

CAUTION: A caution indicates a situation that may result in minor injury.

ATTENTION: Attention indicates a situation that may damage or destroy the product or associated equipment.

NOTE: A note draws attention to important information.

Copyright

© 2014 Extron Electronics. All rights reserved.

Trademarks

All trademarks mentioned in this guide are the properties of their respective owners.

The following registered trademarks[®], registered service marksSM, and trademarksTM are the property of RGB Systems, Inc. or Extron Electronics:

Registered Trademarks [®]
AVTrac, Cable Cubby, CrossPoint, eBUS, EDID Manager, EDID Minder, Extron, Flat Field, GlobalViewer, Hideaway, Inline, IP Intercom, IP Link, Key Minder, LockIt, MediaLink, PlenumVault, PoleVault, PowerCage, PURE3, Quantum, SoundField, SpeedMount, SpeedSwitch, System INTEGRATOR, TeamWork, TouchLink, V-Lock, VersaTools, VN-Matrix, VoiceLift, WallVault, WindoWall, XTP and XTP Systems
Registered Service MarkSM : S3 Service Support Solutions
Trademarks TM
AAP, AFL (Accu-Rate Frame Lock), ADSP (Advanced Digital Sync Processing), Auto-Image, CDRS (Class D Ripple Suppression), DDSP (Digital Display Sync Processing), DMI (Dynamic Motion Interpolation), Driver Configurator, DSP Configurator, DSVP (Digital Sync Validation Processing), FastBite, FOXBOX, IP Intercom HelpDesk, MAAP, MicroDigital, ProDSP, QS-FPC (QuickSwitch Front Panel Controller), Scope-Trigger, SIS, Simple Instruction Set, Skew-Free, SpeedNav, Triple-Action Switching, XTRA, ZipCaddy, ZipClip



Contents

Introduction 1

- About this Manual..... 1
- Terms Used in this Manual..... 1
- Features 1

Installation 3

- Application Examples 3
- Mounting the XTRA Series Amplifiers..... 4
 - Tabletop Use 4
 - UL Guidelines for Rack Mounting..... 4
 - Rack Mounting 5
 - Flexible Conduit Adapter Kit Installation 6

Operation..... 9

- Front Panel Features and Operation 9
- Rear Panel Features and Operation 11
 - Remote Volume Control..... 17
 - Controlling Multiple Amplifiers with One Volume Controller 18
 - Bridged Mono Output..... 19

Troubleshooting 20

- Amplifier Fails to Exit Standby Mode Promptly 20
- Amplifier Enters Standby Mode Too Early 21
- Limiter/Protect LED Warning Indicators 21
- Over Temp Indicator LED..... 21

Introduction

About this Manual

This manual contains information about the Extron XTRA Series of power amplifiers.

- XPA 1002 two-channel stereo audio power amplifier
- XPA 1002 Plus two-channel stereo audio power amplifier
- XPA 2001-70V mono audio power amplifier
- XPA 2001-100V mono audio power amplifier

Terms Used in this Manual

The terms “amplifier” and “power amplifier” are used interchangeably in this manual to refer to all of the XPA models. “XPA 1002” refers to the 1002 and the 1002 Plus. “XPA 2001” refers to both the XPA 2001-70V and the XPA 2001-100V.

Features

Inputs — Balanced or unbalanced stereo or mono on a 3.5 mm, 5-pole captive screw connector.

Speaker outputs — Screw-lock, 5 mm captive screw connectors enable simple, secure connections with 22 AWG to 12 AWG speaker cables.

Continuous power output for larger rooms —

- XPA 1002: 60 watts rms per channel at 8 ohms; 100 watts rms per channel at 4 ohms.
- XPA 1002 Plus: 100 watts rms per channel at 4 and 8 ohms.
- XPA 2001-70V: 200 watts rms for 70 volt speaker systems.
- XPA 2001-100V: 200 watts rms for 100 volt speaker systems.

Professional grade amplifier design —

- The XPA 1002 and 1002 Plus features less than 0.05% total harmonic distortion plus noise, and better than 105 dB signal-to-noise ratio.
- The XPA 2001 features less than 0.1% total harmonic distortion plus noise, and better than 100 dB signal to noise ratio.

ENERGY STAR® qualified amplifier — The XTRA Series of amplifiers are energy efficient products that conserve energy and reduce operating costs.

Highly efficient Class D amplifier design — The XTRA Series of amplifiers generate substantially less heat than conventional amplifier designs, making them ideal for installation in equipment racks and lecterns with very limited ventilation. They consume 10 watts when idle and less than 1 watt in standby mode.

Extron patented CDRS — Class D ripple suppression — A patented, exclusive technology from Extron that eliminates the high frequency switching ripple and EMI emissions found in typical Class D amplifiers. CDRS enables Extron power amplifiers to be situated near wireless AV devices without RF interference.

Convection cooled — The XTRA Series of amplifiers are convection cooled without the need for fans, ensuring quiet, reliable operation.

Ultra low inrush current — no need for power sequencing — Allows many XTRA series amplifiers to be powered on simultaneously without overloading power circuits. This eliminates the need for power sequencing.

Flexible Conduit Adapter Kit — Suitable for use in other environmental air space in accordance with section 300.22, (C) of the National Electrical Code only when used with optional Flexible Conduit Adapter Kit.

Auto-standby with fast power-up — The amplifiers automatically enter into a standby mode after 25 minutes of inactivity, + or - 5 minutes, dramatically reducing power consumption. They quickly return to full power status upon signal detection.

Rear panel attenuation (level) controls — Provide attenuation of input signals for setting proper audio system gain staging as well as two-zone applications. They are located on the rear panel to prevent unauthorized or accidental tampering of the level adjustments.

Multiple protection circuits — Activates during excessive clipping, output shorts, thermal overload, or DC faults to prevent damage to the amplifier and speakers.

Remote standby port — Enables the amplifiers to be remotely powered down when not in use, reducing operating cost.

Remote volume and mute control port — Allows the XPA 1002 series and the XPA 2001 series to be remotely controlled using the optional Extron VCM 100 Series volume and mute or VC 50 volume controllers.

Bridgeable outputs — The power output of the XPA 1002 and XPA 1002 Plus can be effectively doubled by bridging the output. A mono source is wired to both the left and right input while the output is wired for bridged operation. Bridging allows power to be output at 200 watts into 8 ohms. The minimum load impedance when bridging is 8 ohms (see the wiring instructions on page 19).

Front and rear-mounted signal and protection indication LEDs — Provide convenient indication of amplifier operation from both sides of an equipment rack.

Internal international power supply — The 100-240 VAC, 50-60 Hz universal power supply provides worldwide power compatibility.

Installation

This section discusses how to install the XTRA Series of audio power amplifiers. Topics that are covered, include:

- [Application Examples](#)
- [Mounting the XTRA Series Amplifier](#)

WARNING: Failure to follow these instructions may result in serious injury. Installation and service must be performed by authorized personnel only (see [UL Guidelines for Rack Mounting](#) on page 4).

Application Examples

The following illustrations are application examples for the XPA 1002 series and the XPA 2001 series.

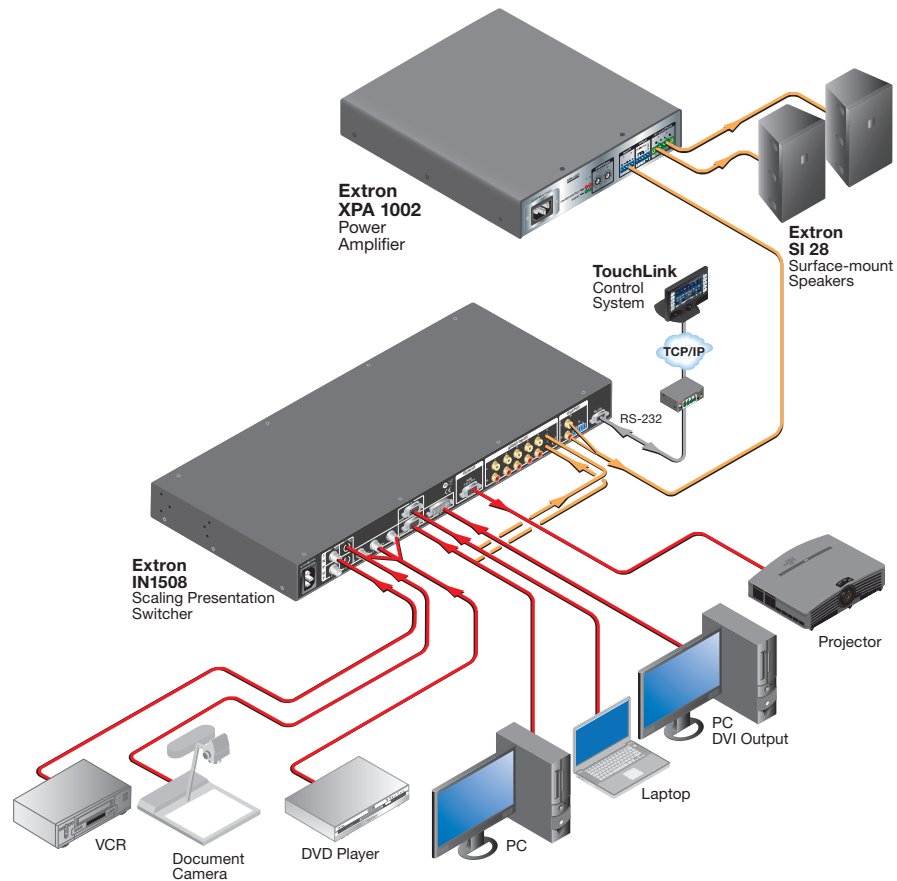

Figure 1. XPA 1002 Series Application Example

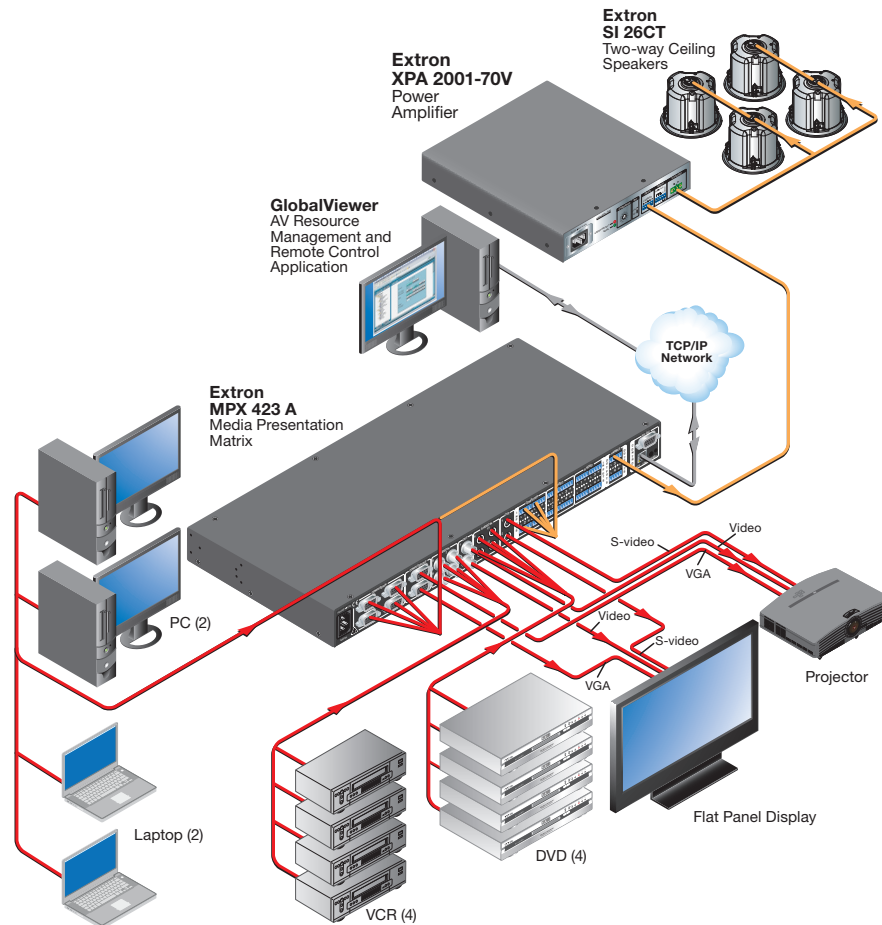

Figure 2. XPA 2001 Series Application Example

Mounting the XTRA Series Amplifiers

The XPA 1002 series and XPA 2001 series of audio amplifiers can be set on a table, mounted on a rack shelf, or mounted in the plenum space above a ceiling-mounted projector.

Tabletop Use

Four self-adhesive rubber feet are included with the audio amplifier.

For tabletop use, attach one foot at each corner of the bottom side of the unit and place the unit in the desired location.

UL Guidelines for Rack Mounting

The following Underwriters Laboratories (UL) guidelines pertain to the installation of the equipment in a rack.

- 1. Elevated operating ambient** — If installed in a closed or multi-unit rack assembly, the operating ambient temperature of the rack environment may be greater than room ambient. Therefore, consider installing the equipment in an environment compatible with the maximum ambient temperature specified by the manufacturer [T_{ma} = +32 to +122 °F (0 to +50 °C)].

2. **Reduced air flow** — Installation of the equipment in a rack should be such that the amount of air flow required for safe operation of the equipment is not compromised.
3. **Mechanical loading** — Mounting of the equipment in the rack should be such that a hazardous condition is not achieved due to uneven mechanical loading.
4. **Circuit overloading** — Consideration should be given to the connection of the equipment to the supply circuit and the effect that overloading of the circuits might have on overcurrent protection and supply wiring. Appropriate consideration of equipment nameplate ratings should be used when addressing this concern.
5. **Reliable earthing (grounding)** — Reliable earthing of rack-mounted equipment should be maintained. Particular attention should be given to supply connections other than direct connections to the branch circuit (such as the use of power strips).

Rack Mounting

The XPA 1002 series and XPA 2001 series can be mounted in a rack shelf using the optional RSU 129 1U Universal rack shelf or the 1U Basic rack shelf, as follows.

1. If feet were installed on the bottom of the amplifier, remove them.
2. Place the amplifier on one half of the rack shelf.
3. Align the front of the amplifier with the front of the shelf, and align the threaded holes on the bottom of the amplifier with the holes in the rack shelf.
4. Attach the amplifier to the rack shelf with the two provided 4-40 x 3/16" machine screws.
5. Insert the screws from the underside of the shelf, and securely fasten them into diagonally-opposite corners.

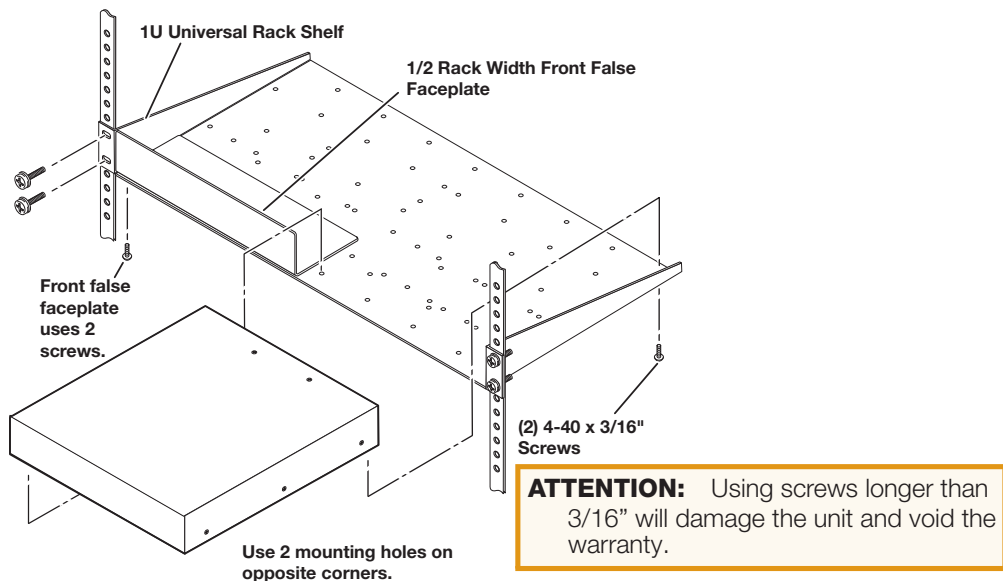

Figure 3. Rack Mounting of the Amplifier

6. Attach the false front panel (provided with rack shelf) to the unoccupied side of the rack (as shown above), or install a second half-rack-width device in that side by repeating steps 1 through 5.
7. Attach the rack shelf to the rack using four 10-32 x 3/4" bolts (provided). Insert the bolts through #10 beveled washers, then through the holes in the rack, as shown above.

Rack Mounting Ventilation Recommendations

Excessive heat can decrease the optimal lifetime of the power amplifier. An over temp indicator LED on the front panel of the amplifier lights red whenever the recommended operating temperature has been exceeded (see [Front Panel Features and Operation](#) on page 9).

To reduce the chances for an over temp condition, the XPAs should be arranged in a rack environment so that adequate airflow is available both above and below the XPA whenever possible. No more than two XPAs should be arranged one-on-top-of-the-other in a rack without an open space between them, as shown in the following illustration. An XPA can also be arranged above or below another non-XPA device, but there must be an open space both above and below those devices.

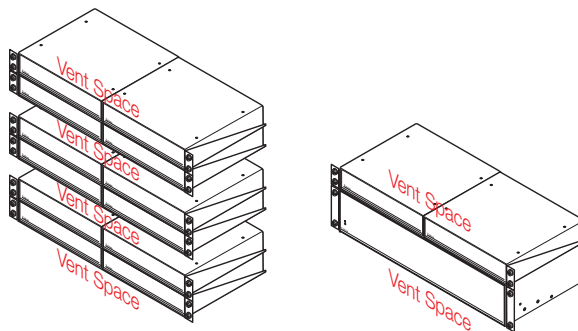

Figure 4. Allow Sufficient Spacing for Adequate Ventilation

Flexible Conduit Adapter Kit Installation

WARNING: Failure to follow these instructions may result in serious injury.

- The circuit breaker used for this connection should be rated no lower than 20 amps and no greater than 30 amps.
- This unit must be installed in accordance with the National Electrical Code and with all local codes.
- An ALL-POLE MAINS SWITCH with a contact separation of at least 3 mm in each pole shall be incorporated in the electrical installation of the building. The installation shall be carried out in accordance with all applicable installation rules.
- Installation and service must be performed by a qualified electrician only.
- Make sure that the source device and the XPA are turned off and disconnected from the power source before you begin.

ATTENTION: A UL listed electrical distribution box is recommended for the termination of the conduit opposite the XPA (see the following [UL Requirements](#) section on page 7).

The optional Flexible Conduit Adapter Kit consists of:

- One EMT adapter plate
- One 6-foot long electrical conduit
- Three 7.5 feet, 18-gauge spade connector power wires
- One UL-rated zip tie wrap
- Three auxiliary crimp style spade connectors designed for 14- to 16-gauge wires

NOTE: If needed, Extron recommends using a UL-rated crimp tool to terminate the spade connectors. One recommended choice is the Molex crimp tool.

The kit provides a convenient means to replace the IEC power cord of the XPA with conduit, where required by local codes.

UL Requirements

The UL requirements listed below pertain to the installation of the flexible conduit onto a XPA 1002 or XPA 2001.

- This unit is not to be used beyond its rated voltage range.
- This unit must be wired to a UL listed distribution box.

NOTE: The UL approved electrical distribution box is not included with either the XPA or the Flexible Conduit Adapter Kit. The installer is responsible for obtaining and installing the box.

Installing the Flexible Conduit Kit

ATTENTION: Electrostatic discharge (ESD) can damage IC chips even though you cannot feel it. You must be electrically grounded before touching anything inside the XPA. A grounding wrist strap is recommended.

Install flexible conduit to the XPA by following the steps below.

1. Unplug the IEC power cord from the power amplifier.
2. Remove the 8 screws from the top and sides of the XPA and lift off the cover (see figure 5).

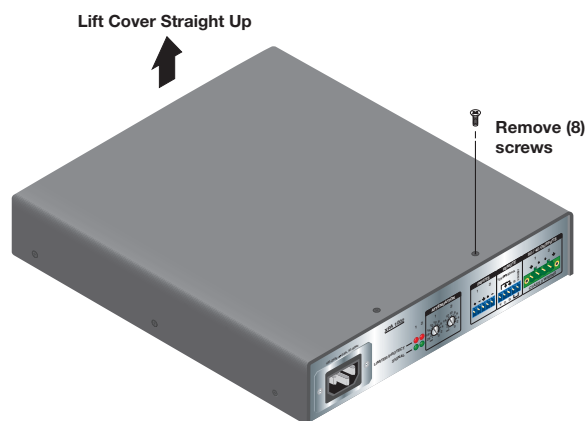

Figure 5. Removing the Cover

3. Remove the 2 screws holding the hot (Line) and neutral wires from the terminal block on the PCB (see figure 6).

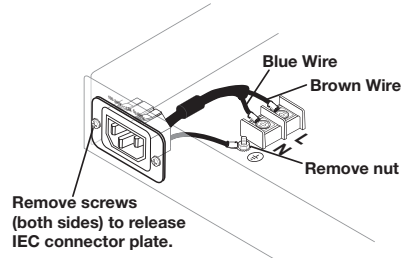

Figure 6. Removing the IEC Connector

4. Remove the ground wire nut from the grounding stud on the bottom of the enclosure, as shown above.
5. Remove the 2 screws from the IEC plate, and remove the IEC connector plate and the attached wires through the rear panel of the XPA, as shown above.
6. Thread the 18-gauge power wires through the length of the electrical conduit tube.
7. Install the EMT adapter plate with conduit attached into the opening from which the IEC connector was removed in step 5.
8. Slide the conduit nut over the bundle of wires exiting the conduit and onto the conduit itself. Hand tighten the conduit nut to the conduit.
9. Attach the EMT adapter plate assembly to the XPA using the 2 screws that were removed in step 5.
10. Connect the black hot (Line) and white neutral wires to the terminal block on the PCB using the 2 screws that were removed in step 3. Use the included zip tie wrap to secure the two wires together close to the terminals (see figure 7).

WARNING: Failure to follow these instructions may result in serious injury.

Ensure that you observe correct wire polarity. The following illustration shows the location of the hot (Line) and neutral terminals.

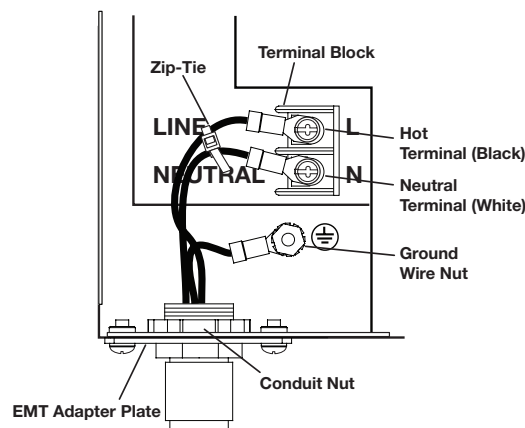

Figure 7. Installing the EMT Adapter Plate Assembly

11. Secure the ground wire, as shown above, to the grounding stud on the bottom of the enclosure using the nut that was removed in step 4.
12. Replace the cover of the XPA by attaching the 8 screws that were removed in step 2.

Operation

This section discusses how to operate the XTRA Series of audio power amplifiers. Topics covered, include:

- [Front Panel Features and Operation](#)
- [Rear Panel Features and Operation](#)

Front Panel Features and Operation

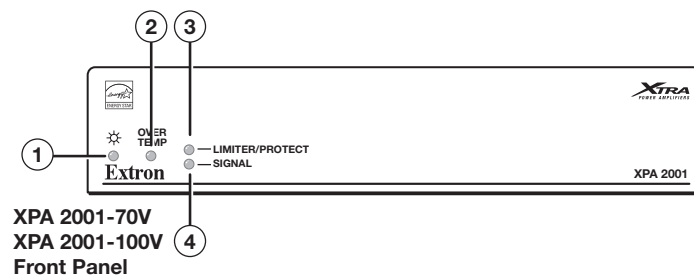
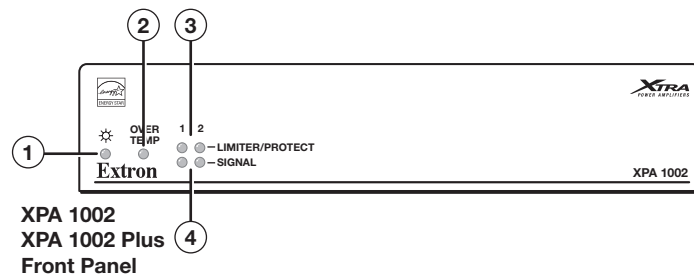

- ① **Power indicator LED** — This LED lights:
 - Green when the amplifier is receiving full power.
 - Amber when the amplifier is in Standby mode. Standby mode turns off all outputs from the amplifier, although the amplifier is still receiving power (see ⑥ of [Rear Panel Features and Operation](#) on page 13).
- ② **Over Temp indicator LED** — This LED lights red when the amplifier exceeds the recommended operating temperature for optimal lifetime. The LED turns off after the amplifier has cooled down sufficiently.

Should the LED light, check the following:

- Verify that the placement of the amplifier allows for adequate ventilation and airflow.
- Avoid placing other equipment on top of the amplifier.
- Verify that the ambient temperature is within the specified range.

- ③ **Limiters/Protect indicator LEDs** — These LEDs (representing their respective output channels) light red under three circumstances:

1 2
● ● — **LIMITER/PROTECT**

- When the output wiring is shorted together.
- When audio clipping occurs, the LED of the corresponding channel blinks once per clip occurrence.
- When the amplifier overheats, both LEDs are lit. The LEDs are not lit after the amplifier recovers from the overheated condition.

NOTE: These LEDs are duplicated on the rear panel.

- ④ **Signal indicator LEDs** — These LEDs (representing their respective output channels) light green only when an input signal is detected on the corresponding channel.

1 2
● ● — **SIGNAL**

NOTE: These LEDs are duplicated on the rear panel.

Rear Panel Features and Operation

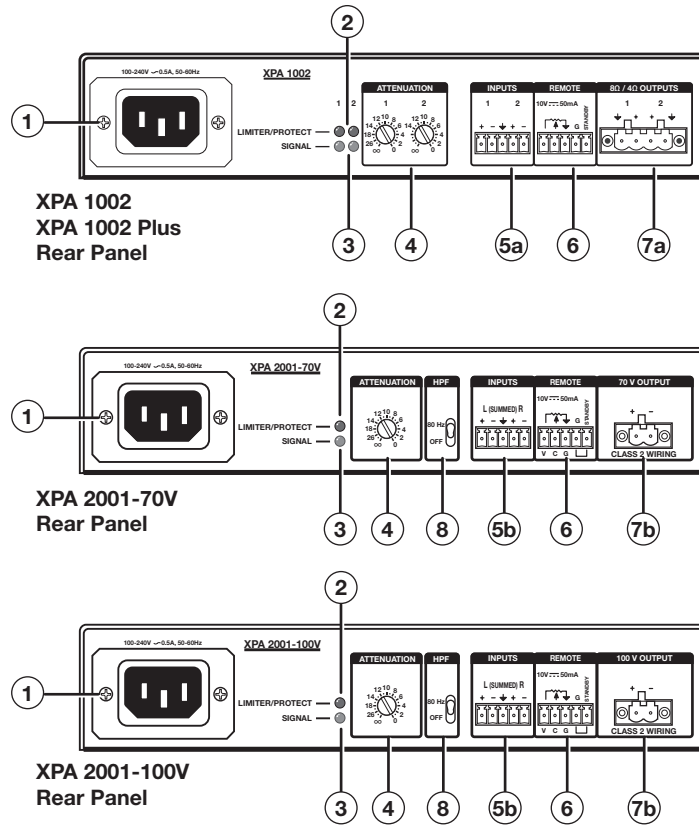

NOTE: Control signal ground pins may be labeled as \oplus , \downarrow , or “G”. Audio ground pins may be labeled as \oplus or \downarrow .
The wiring and function are the same, whichever way your product is labeled.

① **AC power connector** — Connect a standard IEC AC power cord here for power input (100 VAC to 240 VAC, 50 to 60 Hz) to the internal, autoswitching power supply. This connector may be replaced by the Flexible Conduit Adapter Kit as described in [Flexible Conduit Adapter Kit Installation](#) on page 6.

② **Limiter/Protect indicator LEDs** — These LEDs light red under specific circumstances.

NOTE: See ③ of [Front Panel Features and Operation](#) on page 10 for more details.

③ **Signal indicator LEDs** — These LEDs light green only when an input signal is detected on the corresponding channel.

NOTE: See ④ of [Front Panel Features and Operation](#) on page 10 for more details.

- ④ **Attenuation** — Use a small screwdriver to adjust the audio input level for the corresponding channel. The analog potentiometers control the level from ∞ (full attenuation) to 0 dB (no attenuation).

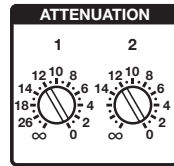

XPA 1002 Series

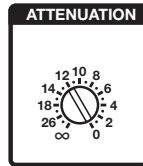

XPA 2001 Series

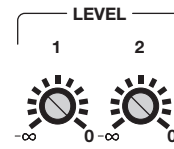

XPA 1002



XPA 2001 Series

NOTES:

- On the XPA 2001 models, the single control adjusts the levels of both channels simultaneously prior to summing them together.
- On some models, this adjustment is referred to as “level”. The function is the same, whichever way your product is labeled.

To adjust the attenuation level of the XPA amplifier, do the following:

1. If connecting to a source device with a volume control (variable output), ensure that the volume on the source device is set to its lowest point, then adjust the attenuation of the XPA fully counterclockwise.
2. Set the volume of the source device to its maximum volume level. No sound should be heard.
3. Return to the XPA amplifier and raise the attenuation until sound distortion occurs, then lower the level slightly to remove any distortion. This setting ensures that, whatever the source device volume setting is, no clipping occurs.

NOTE: When setting volume control through a source device, ensure that the volume of the device is set to variable out. Consult the user manual of the device for detailed instructions on its calibration.

- ⑤a **Balanced or unbalanced stereo or mono audio input connector (XPA 1002 series)** — Wire the 3.5 mm 5-pin captive screw connector for balanced or unbalanced input as show in the diagram on the following page.

NOTE: The power output of the XPA 1002 series amplifiers can be effectively doubled by bridging the output. A mono source is wired to both the left and right input while the output is wired for bridged operation. Bridging allows power to be output at 200 watts into 8 ohms. The minimum load impedance when bridging is 8 ohms (see the wiring instructions beginning on page 19).

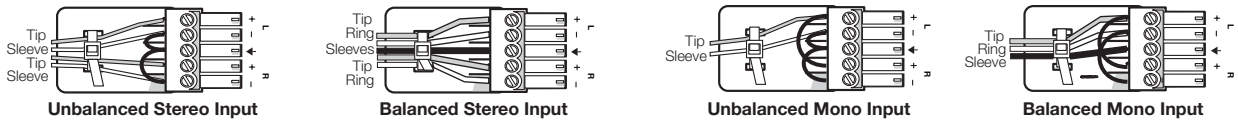

→ ← $\frac{3}{16}$ " MAX.
(5 mm)
Do not tin the wires!

NOTE: The input connector receptacle may be labeled one of two ways. The wiring and function are the same, whichever way your product is labeled.

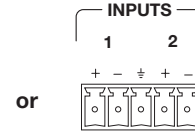
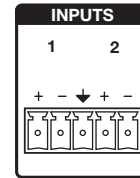

5b) Balanced or unbalanced stereo or mono audio input connector (XPA 2001) — Wire the 3.5 mm 5-pin captive screw connector for balanced or unbalanced input.

NOTE: For mono input on the XPA 2001, because the left and right channels are summed, only wire the left channel. No jumpering to the right channel is needed.

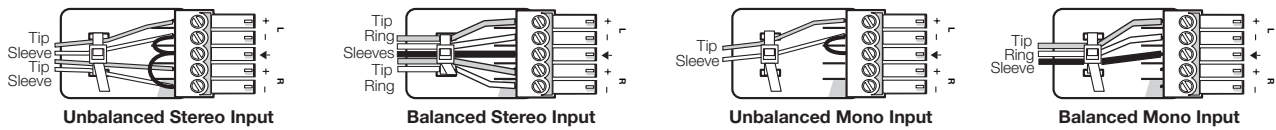

→ ← $\frac{3}{16}$ " MAX.
(5 mm)
Do not tin the wires!

NOTE: The input connector receptacle may be labeled one of two ways. The wiring and function are the same, whichever way your product is labeled.

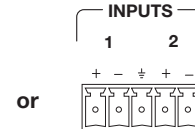
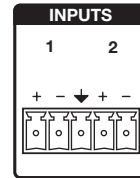

6) Remote control connector — The 3.5 mm 5-pin captive screw port is used to remotely control two functions through contact closure (see the circuit diagram on the following page).

NOTE: The remote control port may be labeled one of two ways (see the image on the following page). The wiring and function are the same, whichever way your product is labeled.

Pins V, C, and G (1, 2, and 3) control volume by varying the DC voltage from 0 V (full attenuation) to 10 V (maximum volume) with full muting in effect when pin C is connected to ground (pin G). Use the included 3-pin captive screw connector (see [Remote Volume Control](#) on page 17).

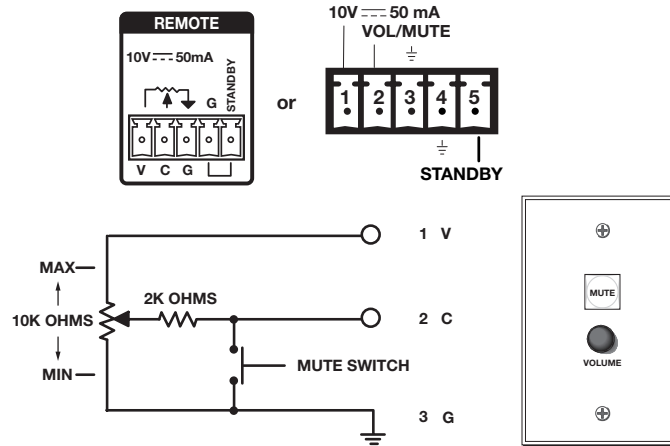

Pin 5 (standby) connected to ground (pin 4) places the amplifier in standby mode. Standby mode turns off all output, although the amplifier is still receiving power. Use the included 2-pin, 3.5 mm captive screw connector to remotely ground pin 5. The power indicator LED lights amber when the amplifier is in standby mode.

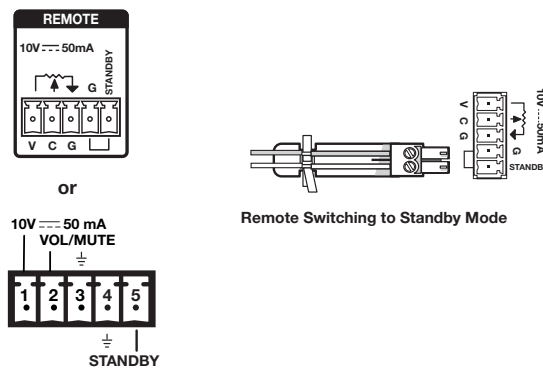

7a) Stereo audio output connector — Marked “1” and “2” for the output channels, wire the included 4-pole, 5 mm screw lock captive screw connector to output stereo audio. Observe the correct polarities for each channel (see the following steps). The output is designed to power 4 or 8 ohm speaker systems and is rated for 100 watts per channel at 4 ohms and 60 watts per channel at 8 ohms for the non-Plus model, and 100 watts per channel at 4 and 8 ohms for the Plus model.

NOTES:

- You must use Class 2 wiring for this output to comply with UL requirements.
- The stereo audio output connector may be labeled one of two ways (see the images on the following page). The wiring and function are the same, whichever way your product is labeled.

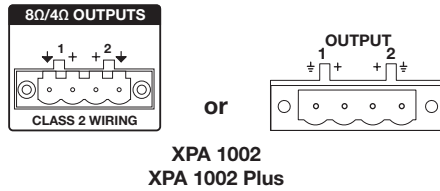

ATTENTION: Do not tie channel outputs 1 and 2 to each other or to ground. Doing so will short the outputs, damage the amplifier, or both.

NOTE: The power output of the XPA 1002 series can be effectively doubled by bridging the output. A mono source is wired to both the left and right input while the output is wired for bridged operation. Bridging allows power to be output at 200 watts into 8 ohms. The minimum load impedance when bridging is 8 ohms (see the wiring instructions beginning on page 19).

To wire the stereo audio output connector:

Step 1: Strip and insert the speaker wires into the connector and tighten the captive screws. Be sure to observe the correct polarity.

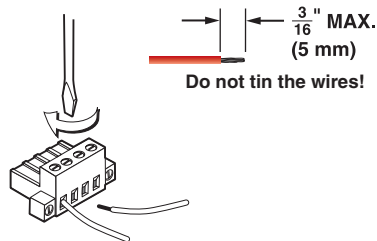

Step 2: Insert the wired connector into the amplifier output and secure the locking screws on either side.

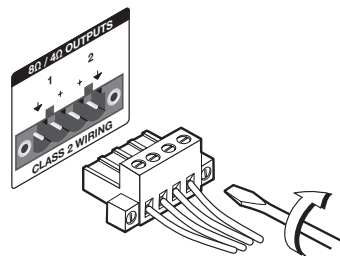

- 7b Mono audio output connector** — Wire the included 2-pole, 5 mm screw lock captive screw connector for mono audio (see the steps below). Output is designed to power 70 V (XPA 2001-70V) or 100 V (XPA 2001-100V) line distribution systems and is rated at 200 watts.

NOTES:

- You must use Class 2 wiring for this output to comply with UL requirements.
- The mono audio output connector may be labeled one of two ways (see the images below). The wiring and function are the same, whichever way your product is labeled.

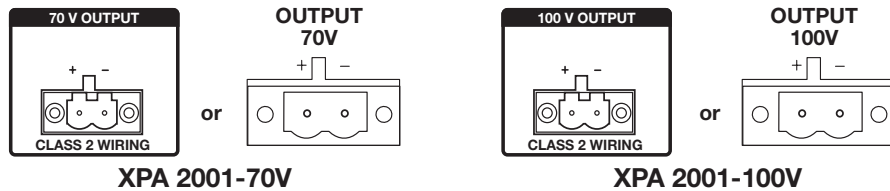

ATTENTION: Do not tie channel outputs 1 and 2 to each other or to ground. Doing so will short the outputs, damage the amplifier, or both.

To wire the mono audio output connector:

Step 1: Strip and insert the speaker wires into the connector and tighten the captive screws. Be sure to observe the correct polarity.

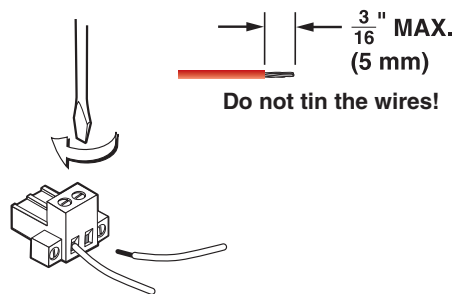

Step 2: Insert the wired connector into the amplifier output and secure the locking screws on either side.

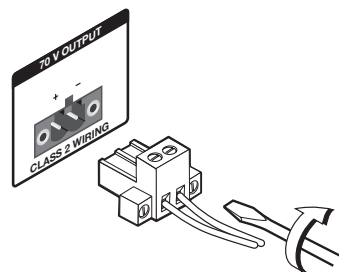

- ⑧ **High pass filter (HPF) toggle switch (XPA 2001 series)** — Use a small screwdriver to toggle this recessed two-position switch. Setting the switch to 80 Hz (default) prevents the saturation of 70 V and 100 V speaker input transformers by low frequency signals. Saturation can result in severe distortion of the speaker output signal.

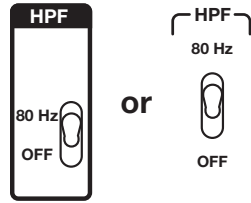

NOTES:

- The filter may be safely turned off if high pass filtering is applied to the source input signal upstream of the amplifier. Otherwise, it should be left on.
- The high pass filter toggle switch may be labeled one of two ways. The wiring and function are the same, whichever way your product is labeled.

Remote Volume Control

Options for the remote control of the XPA amplifiers include the Extron VCM 100 and VC 50 volume controllers. Third party 10k potentiometer volume controllers can also be connected to this port.

As shown in the following illustration, pin V (1) on the XPA is a 10 VDC reference voltage. Pin C (2) is the volume control DC voltage input. The range is 0 to 10 V, where 0 V is mute and 10 V provides maximum volume. Pin G (3) is ground.

NOTE: All nominal levels are at $\pm 10\%$.

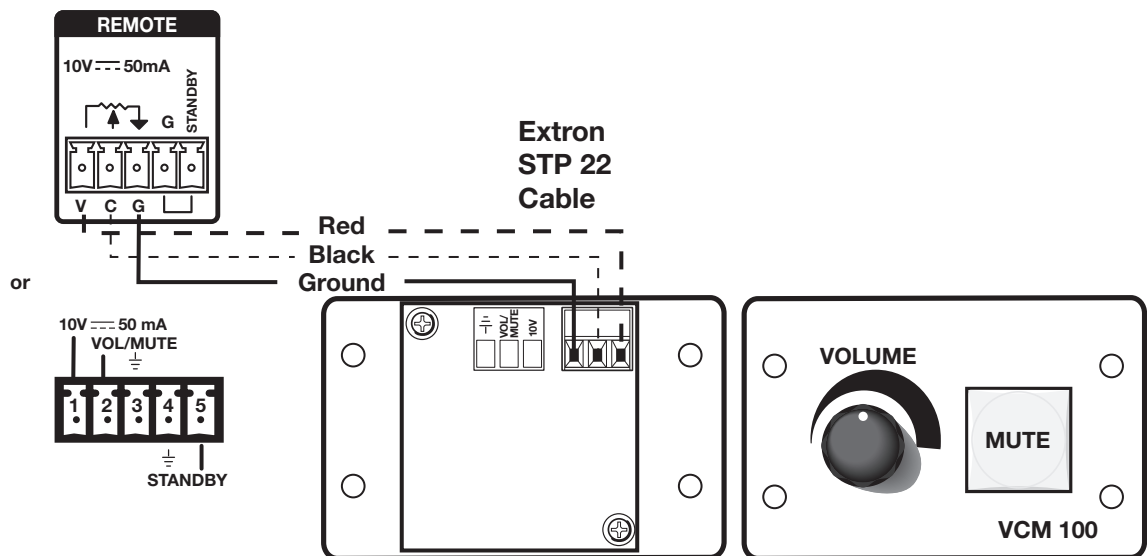

Figure 8. Pinout Diagram for VCM 100 MAAP Connection to XPA Remote Connector

Controlling Multiple Amplifiers with One Volume Controller

Several XPA 1002 and XPA 2001 series units can be daisy-chained so that one volume controller can simultaneously regulate the volume of all the amplifiers.

NOTES:

- As additional amplifiers are added to the daisy chain, the sensitivity of the volume potentiometer will change. The maximum volume level (fully clockwise) will not be affected. However, the effectiveness of the minimum volume level (fully counterclockwise) in reducing the volume to inaudible levels decreases as more amplifiers are added to the daisy chain.
- When more than two XPA Half-Rack units are attached to the chain, sound may be heard even if the levels have been set to their lowest. If complete muting is required, use a contact closure switch attached between the C (Vol/Mute) and the G (ground) pins of the first XPA Half-Rack unit in the chain.

To regulate multiple amplifiers with a single volume controller:

1. Attach all three pins of the volume controller to the corresponding pins on the first XPA Half-Rack unit only — Ground to G (ground), Vol/Mute to C (Vol/Mute), and 10 V to V (10 V).
2. Use jumper wires to connect the C (Vol/Mute) pins of the first amplifier and each successive amplifier.
3. Use jumper wires to connect the G (ground) pins of the first amplifier and each successive amplifier.

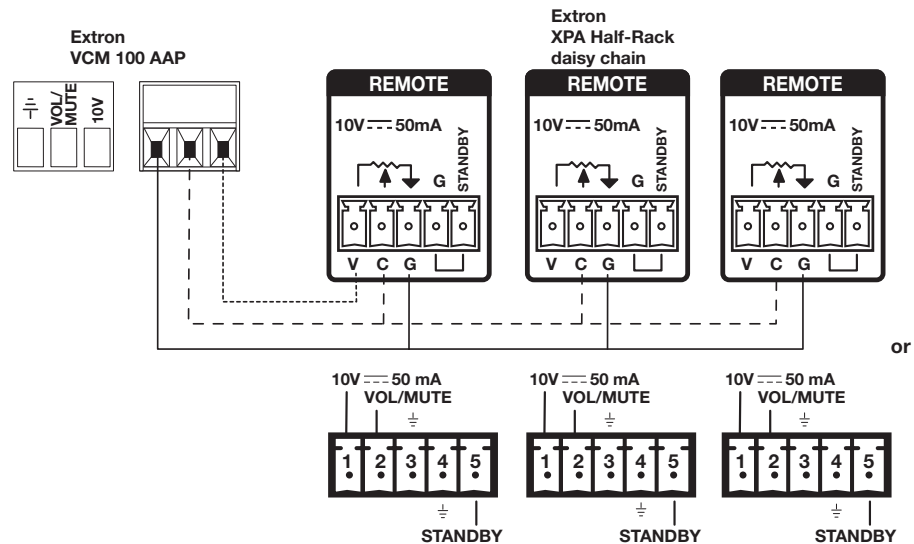

Figure 9. Regulating Multiple Amplifiers with a Single Volume Controller

NOTE: The 10 V pin of the volume controller connects to the first XPA Half-Rack unit only. There are no jumper wires linking it to subsequent amplifiers.

Bridged Mono Output

The power output of the XPA 1002 and XPA 1002 Plus can be effectively doubled by bridging the output. Bridging allows power to be output in mono at 200 watts at 8 ohms.

NOTES:

- The bridging instructions that follow apply only to the XPA 1002 series.
- The minimum load impedance when bridging is 8 ohms.

To bridge the output, follow the steps and refer to the diagram below:

1. Unplug the IEC power cord from the power amplifier.
2. Fully attenuate the potentiometer.
3. Wire the output as shown in the following diagram.
4. Wire the input as shown in the following diagram.
5. Connect the IEC power cord and power up the amplifier.
6. Adjust the input levels of channels 1 and 2 identically.

NOTE: See ④ (Attenuation) of [Rear Panel Features and Operation](#) on page 12 for more details.

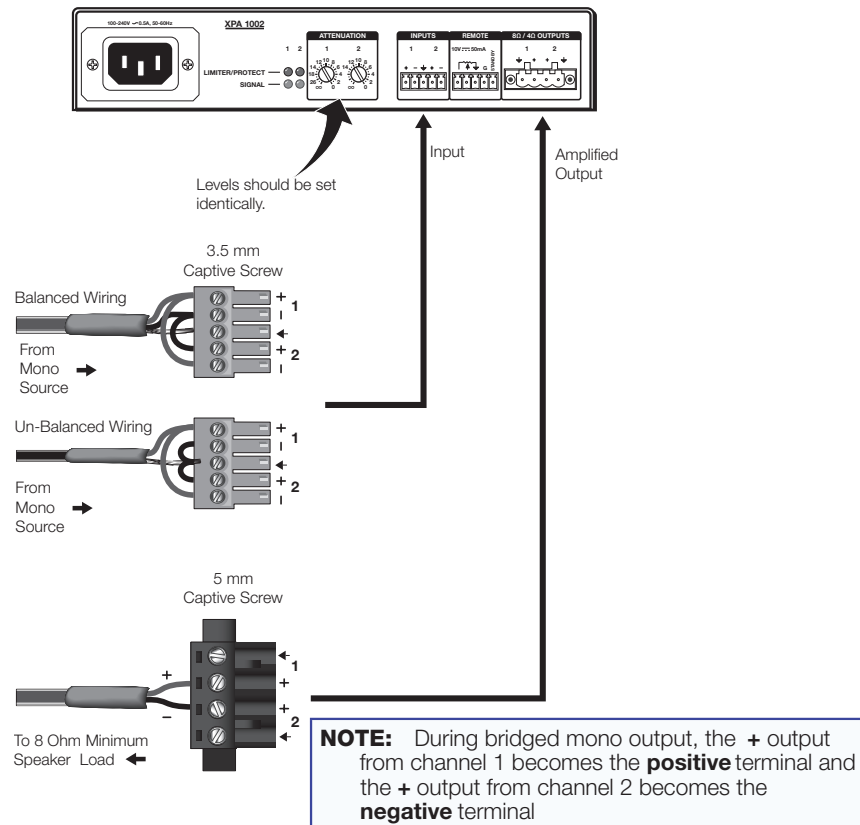

Figure 10. Bridging the Output of the XPA 1002 Series

Troubleshooting

The front and rear panels have LED warning indicators, as described in the following diagnostic information.

Amplifier Fails to Exit Standby Mode Promptly

The input channel (channels 1 and 2) Signal LED lights green per indicated input channel when an input signal is detected.

Power LED Color	Signal LED State	Problem Description	Problem Solution
Amber	Not lit	No output signal	No input detected, verify the input signal. If input is present, raise input level until signal LED lights.
Green or Amber	Lit intermittently	Does not promptly exit standby mode with signal present.	The output signal level of the source may be too low to cross the signal detection threshold of the amplifier (see amplifier specifications for details). Increase the signal level of the source until the signal LED lights consistently.
Amber	Lit	No output signal	Amplifier has been placed in standby mode and output has been turned off. Check remote port. DC Fault may have been detected (see below).
Amber	Lit	DC Fault is detected on either channel. Unit does not exit standby.	Disconnect power then disconnect the remote port (if connected). Next, reconnect power to the unit to determine if the unit continues to go into immediate standby upon power up. In such a case, the unit should be serviced.

Amplifier Enters Standby Mode Too Early

The input channel (channels 1 and 2) Signal LED lights green per indicated input channel when an input signal is detected.

Power LED Color	Signal LED State	Problem Description	Problem Solution
Green or Amber	Lit intermittently	Enters standby mode early.	The output signal level of the source may be too low to cross the signal detection threshold of the amplifier (see amplifier specifications for details). Increase the signal level of the source until the signal LED lights consistently.

Limiter/Protect LED Warning Indicators

The output channel (channels 1 and 2) Limiter/Protect LED lights red per indicated output channel as shown in the following diagnostic information.

LED State	Problem Description	Problem Solution
Blinks	Audio clipping is occurring at the rate of one blink per clip.	Reduce the power output to avoid overdriving the amplifier, causing clipping.
Lights steady	The amplifier may be overheating.	Determine the reason for the overheated state and allow the amplifier to cool. The LED will not be lit after the amplifier recovers from the overheated state.
	Output channel leads are shorted	Check speakers and speaker wiring for shorts.

Over Temp Indicator LED

This indicator does not represent a hard failure of the unit. It is meant as a warning that the amplifier has exceeded the recommended operating temperature for optimal product lifetime.

LED State	Problem Description	Problem Solution
Lights steady	Amplifier has exceeded the recommended operating temperature. The LED turns off after the amplifier cools down sufficiently.	<ul style="list-style-type: none">• Verify that the placement of the amplifier allows for adequate ventilation and airflow.• Avoid placing equipment on top of the amplifier.• Verify that the ambient temperature is within the specified range.

Extron Warranty

Extron Electronics warrants this product against defects in materials and workmanship for a period of three years from the date of purchase. In the event of malfunction during the warranty period attributable directly to faulty workmanship and/or materials, Extron Electronics will, at its option, repair or replace said products or components, to whatever extent it shall deem necessary to restore said product to proper operating condition, provided that it is returned within the warranty period, with proof of purchase and description of malfunction to:

**USA, Canada, South America,
and Central America:**

Extron Electronics
1230 South Lewis Street
Anaheim, CA 92805
U.S.A.

Japan:

Extron Electronics, Japan
Kyodo Building, 16 Ichibancho
Chiyoda-ku, Tokyo 102-0082
Japan

Europe and Africa:

Extron Europe
Hanzeboulevard 10
3825 PH Amersfoort
The Netherlands

China:

Extron China
686 Ronghua Road
Songjiang District
Shanghai 201611
China

Asia:

Extron Asia Pte Ltd
135 Joo Seng Road, #04-01
PM Industrial Bldg.
Singapore 368363
Singapore

Middle East:

Extron Middle East
Dubai Airport Free Zone
F12, PO Box 293666
United Arab Emirates, Dubai

This Limited Warranty does not apply if the fault has been caused by misuse, improper handling care, electrical or mechanical abuse, abnormal operating conditions, or if modifications were made to the product that were not authorized by Extron.

NOTE: If a product is defective, please call Extron and ask for an Application Engineer to receive an RA (Return Authorization) number. This will begin the repair process.

USA: 714.491.1500 or 800.633.9876
Asia: 65.6383.4400

Europe: 31.33.453.4040
Japan: 81.3.3511.7655

Units must be returned insured, with shipping charges prepaid. If not insured, you assume the risk of loss or damage during shipment. Returned units must include the serial number and a description of the problem, as well as the name of the person to contact in case there are any questions.

Extron Electronics makes no further warranties either expressed or implied with respect to the product and its quality, performance, merchantability, or fitness for any particular use. In no event will Extron Electronics be liable for direct, indirect, or consequential damages resulting from any defect in this product even if Extron Electronics has been advised of such damage.

Please note that laws vary from state to state and country to country, and that some provisions of this warranty may not apply to you.

Extron Headquarters +1.800.633.9876 (Inside USA/Canada Only) Extron USA - West +1.714.491.1500 +1.714.491.1517 FAX Extron USA - East +1.919.850.1000 +1.919.850.1001 FAX	Extron Europe +800.3987.6673 (Inside Europe Only) +31.33.453.4040 +31.33.453.4050 FAX	Extron Asia +800.7339.8766 (Inside Asia Only) +65.6383.4400 +65.6383.4664 FAX	Extron Japan +81.3.3511.7655 +81.3.3511.7656 FAX	Extron China +4000.398766 Inside China Only +86.21.3760.1568 +86.21.3760.1566 FAX	Extron Middle East +971.4.2991800 +971.4.2991880 FAX	Extron Korea +82.2.3444.1571 +82.2.3444.1575 FAX	Extron India 1800.3070.3777 Inside India Only +91.80.3055.3777 +91.80.3055.3737 FAX
--------------------------------------------------------------------------------------------------------------------------------------------------------------------------------------------------------------------	----------------------------------------------------------------------------------------------------------	--------------------------------------------------------------------------------------------------	---------------------------------------------------------------	------------------------------------------------------------------------------------------------------	-------------------------------------------------------------------	---------------------------------------------------------------	--------------------------------------------------------------------------------------------------------